



Seal Probe Wiring

The mechanical seal leak detector probe utilized in the pump is a conductive probe which is normally open. The intrusion of water into the seal chamber completes the electrical circuit. Control panel provisions must be made to sense this circuit closure, and to provide indication or alarm functions depending on the panel design.

Either single or dual wire systems may be provided. Single wire systems utilize one energizing conductor, and the pump casing and neutral lead as the ground or return portion of the circuit. The dual wire systems utilize two conductors, one for each leg of the circuit.

With either system, the seal probe leads must be wired into a control circuit provided in the control panel. This control circuit must energize the probe with a regulated power source, and sense the closed circuit in event of water intrusion. Indication and alarm functions must also be provided in the control circuit. Please see control panel wiring diagram for seal probe connection points. **IMPORTANT:** For Hazardous Area Classification Pumps, leak detector circuit must be in conformance with applicable NEC codes and regulations.

Single Wire Seal Probe Diagram

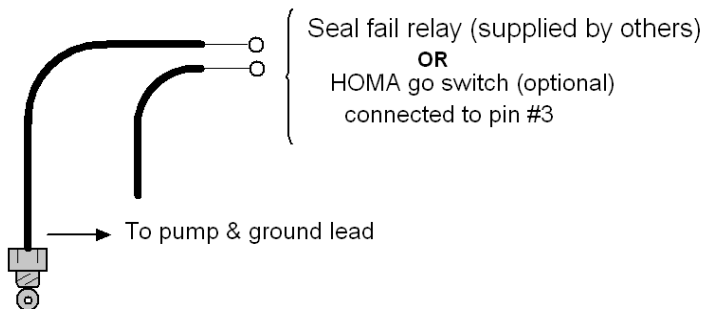

Double Wire Seal Probe Diagram

