



GRP Series

Installation, Operation & Maintenance Manual

Project: _____

Installation: _____

Pump Model: _____ Serial Number: _____

PN# GRPIOM REV. 2/11

HOMA Pump Technology, Inc.
390 Birmingham Boulevard • Ansonia, CT 06401

GENERAL INSTRUCTIONS:

This manual is intended to provide basic installation and start-up guidance. It is to be read and thoroughly studied prior to attempting to install or operate any of the equipment supplied. *Equipment damage, which occurs by not following these instructions will void the warranty.*

SAFETY PRECAUTIONS:

Only trained qualified personnel shall be utilized for installation and start-up.

The following is a general list of safety precautions that should be followed when installation starting-up or servicing the pump. **The pump station owner or operator is ultimately responsible for ensuring that all equipment is installed, started up and operated in a safe manner.**

- Do not work alone.
- Double check to make sure that all lifting equipment is in good working order and that it has adequate lifting capacity for the weight that it will handle.
- Wear safety helmet, goggles and protective shoes, or appropriate safety materials required.
- Before working on the pump make sure that power is disconnected and cannot be energized by others. Lockout and tag the control panel circuit breaker.
- Do not stand under suspended loads!
- Never enter or work within a wet well without first checking to make sure sufficient oxygen is present and that there are no explosive or poisonous gases present.
- All personnel, who work with sewage pumping equipment and systems shall be vaccinated against diseases that can occur, If there are any questions or doubts in this area it is strongly suggested that the local health agency be contacted.
- For Hazardous Area Classifications, only use pumps with suitable Explosion Proof Rating.

EQUIPMENT INVENTORY AND INSPECTION:

Upon arrival of pump shipment carefully unpack all components and compare with shipping and purchase order documents to ensure that the order is complete. Also inspect equipment for any damage that might have occurred in shipment. *If any problems are detected contact an authorized HOMA Pump Technology Representative immediately.*

TRANSPORTATION AND STORAGE PROCEDURE:

Always lift the pump by its lifting bail or eye. **Never lift the pump by its power cable!** Pumps should be stored in an upright position, taking extreme care to protect the power cable and control cables from crushing, nicks or tears which would permit water intrusion. Power cable ends must be protected from immersion in water as well as moisture intrusion. The cable will wick water into the pump if it is not protected properly. Power cable leads should be covered with shrink tubing or suitable sealing material.

Short Term Storage: Short term storage is defined as any time less than six months. We recommend that pump and accessories be stored in their original shipping container in a dry, temperature controlled area. If climate controlled storage is not possible, all exposed parts should be inspected before storage and all surfaces that have the paint scratched, damaged or worn should be re-coated with suitable paint. When possible it is best to store the pump in an upright position.

Long Term Storage: Any storage time exceeding six months is considered long term. In addition to the safeguards specified above, the impeller should be rotated once a month to prevent the mechanical seals from being damaged, and the pump should be inspected. The oil in the mechanical seal chamber should be drained and replaced prior to commissioning.

ELECTRICAL INSTALLATION:

GENERAL GUIDELINES

All electrical work shall be carried out under the supervision of an authorized, licensed electrician.

The present state adopted edition of the National Electrical Code as well as all local codes and regulations shall be complied with.

VERIFICATION OF POWER SUPPLY

Prior to making any electrical connections or applying power to the pump, compare the power supply available at the pump station to the data on the unit's nameplate. *Confirm that both voltage and phase match between pump and control panel.*

The voltage supplied at the pump shall be +5 / -10% of the nameplate value, frequency shall be + / - 1% of the nameplate value, the voltage phase balance shall be within 1% and the maximum corrected power factor shall be 1.0.

POWER LEAD WIRING

HOMA GRP Series pumps may be provided with 1 or more cables, depending on motor horsepower and operating voltage. Power leads L1, L2, & L3 may be provided as single conductor, or as twin conductor. Twin conductor configuration may use leads from two separate cables, or may use two conductors within one cable. Please refer to wiring diagram in the appendix for specific connection details. *The pump must be connected electrically through a motor starter with proper circuit breaker protection in order to validate warranty. Do not splice cables.*

THERMAL SWITCH WIRING :

Pumps are equipped with thermal switches which are normally closed, automatically resetting switches. Switches will open when the internal temperature rises above the design temperature, and will close when the temperature returns to normal. Non Explosion proof GRP 10/1 to 21/1 single phase pumps have internally connected thermals which shut pump down in the event of over temperature condition, and do not require any external connection. Explosion proof pumps and pumps with 7 lead cable have thermal switches which must be wired into the over temperature circuit of the control panel.

Note: All sizes of Class1, Div. I pumps for hazardous service will have externally wired thermal switches. Thermal switch leads must

be connected to a current regulated control circuit in accordance with the NEC.

Thermal switch leads must be connected to validate warranty.

Identify thermal switch leads marked T1 and T3 in the power or control cable. The resistance across these leads will be .5 Ohm. These leads must be connected to the thermal overload relay such as the HOMA Go switch seal fail / thermal relay (option) or other current regulated power supply / controller.

SEAL PROBE WIRING

The mechanical seal leak detector probe utilized in the pump is a conductive probe which is normally open. The intrusion of water into the seal chamber completes the electrical circuit. Control panel provisions will sense this circuit closure, and will provide indication or alarm functions depending on the panel design.

Either single or dual wire systems may be provided. Single wire systems utilize one energizing conductor, and the pump casing and neutral lead as the ground or return portion of the circuit. The dual wire systems utilize two separate conductors for each leg of the circuit.

With either system, the seal probe leads must be wired into a control circuit provided in the control panel. This control circuit must energize the probe with a regulated power source, and sense the closed circuit in event of water intrusion. Indication and alarm functions must also be provided in the control circuit. Please see control panel wiring diagram (by others) for seal probe connection points. **IMPORTANT: For Hazardous Area Classification Pumps, leak detector circuit must be in conformance with applicable NEC codes and regulations.**

START / RUN CAPACITORS AND RELAYS:

All single phase motors require start and/or run capacitors to operate. Refer to the wiring schematics in the appendix. *Capacitors and relays must be sized for the specific motor.*

Capacitors are sized based on ideal conditions. The Run capacitor may need to be resized to match the available field voltage. Each cap kit shipped is supplied with a wiring diagram and start-up procedure.

MECHANICAL INSTALLATION: **PUMPS WITH AUTOCOUPLING SYSTEMS**

The HOMA Auto-Coupling is a quick removal system used in keeping personnel from having to enter the wet well. The pump mounts on a stationary base and operates completely or partially submerged (min. 8" above volute) in the pumping media.

The HOMA Auto-Coupling kit includes a base elbow, guide claw flange and upper guide rail bracket. Kit also includes a profile seal and base anchor bolts. Refer to dimensional drawing for details.

For GRP 10 - 50 Series pumps with horizontal 2" threaded discharge, attach the guide claw flange to the pump discharge flange as follows:

1. Inspect threaded assemblies for damage.
2. Clean threaded portions of pump discharge flange and guide claw flange and locate set screw location.
3. Install profile seal (if not already installed at factory) into the guide claw with large diameter fitted into groove inside of claw.
4. Apply pipe sealant to the threads of the discharge.
5. Thread guide claw flange on to pump discharge fully. *DISCHARGE THREADS ARE NOT NPT. DO NOT OVER TIGHTEN.*
6. Tighten guide claw flange until the claw is in upright (horizontal) position.
7. Apply thread locker to the set screw included with the guide claw and tighten set screw.

For GRP 12 and 19 Series pumps with vertical, 1¼" threaded discharge (note: this assembly can be ordered with or without integral check valve), attach the pump discharge flange as follows: *Refer to assembly drawing provided with the auto-coupling for additional details.*

1. Inspect threaded assemblies for damage.
2. Clean threaded portions of pump discharge flange, nipple and riser pipe.
3. Apply pipe sealant to the male threads.
4. Thread guide claw riser pipe (either style) onto the pump discharge with the provided 11/4" close nipple. Tighten the assembly until the opening in riser pipe points away from pump and is parallel with the cable entry.

5. Bolt the guide claw flange with rubber gasket to the riser pipe using the SS nuts and bolts provided.
6. Install profile seal (if not already installed at factory) into the guide claw with large diameter fitted into groove inside of claw. Refer to the drawing provided with the kit.
7. For check valve version install second gasket drop in check ball and fasten the cover with nuts and bolts provided.

Important: Do not install more than one (1) check valve into any pump discharge piping system or problems will occur.

For GRP 59 to 118 Series pumps, attach the guide claw flange to the pump discharge flange with the fasteners and gasket included with the auto-coupling kit. Tighten the bolts to the proper torque. Install profile seal (if not already installed at factory) into the guide claw with large diameter fitted into groove inside of claw.

For all pumps, properly locate the base and with the anchor bolts fasten to the floor of the pump station. Make sure when locating and securing the anchor bolts that the base will align properly with the access cover at the top elevation of the station. (Refer to outline drawing in appendix). Level the base before completely tightening the anchor bolts. *If base is not level, proper sealing of the pump to base may not occur!*

Place the guide rail pipes (supplied by others), cut to length into the rings of the base. The rails will be secured at the top of the pump station with the upper guide bar bracket and will extend down to the sump floor.

For stations exceeding 10 feet in depth, intermediate guide bar brackets are recommended. One bracket is recommended for each additional 10 feet of station depth.

Install upper guide bar bracket as shown on outline drawing located in the appendix. Do not tighten mounting bolts completely at this point. Check that the guide system is properly installed in the vertical orientation by using levels and a plumb line. Then tighten upper guide anchor bolts. Connect the station riser piping to the outlet flange of the base.

INSTALLATION OF PUMPS WITH RING STANDS:

The ring stand design allows for simple economical installation and can be transported from one installation to another. It is intended to operate completely or partially submerged in the pumping liquid.

For pump models without integral support feet, install the ring stand to the underside of the volute with the supplied fasteners. Apply a thread locking compound to threads before installing such as Blue Loctite #242.

Install lifting chain or cable of adequate size and load rating of the unit. Allow for proper length to permit proper lowering and raising of the pump. Properly position power cables and lifting device over the load and keep from entering the pump suction.

Prior To Installation:

Before lowering the pump into position check the direction of rotation. The impeller will rotate clockwise as viewed from the top. Therefore the pump will try to move in the counter clockwise direction as the impeller rotates (known as start reaction). "Bump the Motor" by closing the pump circuit breaker and push the pump start button and look for the direction of movement specified above. For three phase motors, if the starting jerk is in the clockwise direction, open the circuit breaker to isolate power and interchange two of the three phase leads inside the control panel.

Make sure to use lifting equipment that has adequate capacity for the pump that will be handled. Before installing pump, check to be certain the profile seal is properly positioned in the guide claw flange. Position pump so the guide ears on the discharge flange engage the rails. Slowly lower the pump along the guide rail. Once the pump reaches its bottom location it will automatically connect to the base.

PUMP MODEL	Bolts Anchors	SIZE	TORQUE
1 ¼ -2" GRP THREADED	4	M12mm	37 ft/ #
2" GRP FLANGED	4	M16x60 M16mm	108 ft/ # 74 ft/ #

Notes:

1. Flange bolts must be tightened in cross pattern to avoid damage to the raise face flanges.
2. Standard Flange Bolts are 316SS
3. Standard Anchors are Plated Steel
4. Autocoupling systems include qty 4 M12 anchors for the upper bracket. Torque to 38 ft#.
5. Anchor bolt holes should be drilled to the actual diameter of the anchor (M12 anchor requires 12mm diameter hole).

START-UP

Prior To Applying Power

Prior to applying power to the pump; double check all wiring and verify that the power (Voltage, Phase) that will be supplied to the unit matches the name-plate specified values. Measure resistance of cable and pump motor resistance of ground circuit between control panel and outside of pump. Perform MEG ohm check of motor insulation. Record all data on start-up checklist which is included with this manual.

Wet Well Applications

If the above checks prove satisfactory the pump is ready for operation. Lower the pump into position. (Refer to Mechanical installation section of this manual.)

Open discharge valve, and verify that all check valves operate freely. It is very common for discharge check valves to be jammed shut (or open) after sitting for a period of time. Once all valves are open and free, start the pump and allow it to stabilize for several minutes prior to recording any test data.

Listen for any unusual noise and be on the lookout for unusual vibration. This is generally detectable on guide rails for Auto Coupling installations and on discharge piping for ring stand installations. Also for Auto Coupling installations, look for any blow by from the discharge connection.

Perform all remaining electrical, operational, and performance tests specified on the start-up report at the back of this manual. *Record and provide details on the checklist to validate warranty.*

Installation / Startup Troubleshooting:

Only authorized service personnel who are trained professionals shall troubleshoot and repair pumps that are experiencing operational or performance difficulties.

All HOMA pumps are factory tested, yet startup difficulties can occur with any mechanical equipment. Please note that our technical support staff stands ready to assist you with any problem or difficulty you might encounter with our equipment.

The following is a tabulation of common start-up problems and possible causes.

Symptom

Possible Causes

Pump will not start

1, 2, 3, 4, 27, 29, 31, 32

Little or zero discharge

5, 6, 7, 8, 16, 30, 32

Insufficient discharge flow/pressure

5, 6, 9, 10, 11, 12, 26, 30

Excessive power consumption

6, 9, 13, 28, 30

Excessive current draw

6, 13, 14, 15, 19, 21, 26, 30

Excessive pump vibration/noise

5, 7, 9, 10, 12, 13, 15, 16, 17, 25, 26, 30, 31

Pumps runs & motor protection trips

17, 18, 19, 20, 21, 28

Pumps runs manually, but not automatically

22, 23, 24

Pump runs hot

7, 13, 18, 19, 25, 26, 28

Listing of Possible Causes:

1. Incorrect or no power supplied to motor.
2. Power cable cut.
3. Short to ground in cable or motor winding.
4. Control panel circuit breaker open.
5. Actual system head is higher than calculated or specified.
6. Incorrect impeller rotation direction.
7. Sump liquid level is below pump's minimum submergence requirement.
8. Closed discharge valve or jammed check valve.
9. Wear ring(s) worn. (If Applicable).
10. Vortex at pump's suction.
11. Discharge valve partially closed.
12. Insufficient NPSHA (Dry Pit Application).
13. Actual system head is lower than specified resulting in over pumping condition.
14. Voltage supply to motor is lower than required by motor.
15. Damaged bearings.
16. High system head causing pump to operate at extremely reduced capacity.
17. Object stuck inside impeller.
18. Motor not receiving proper voltage on all three phases.
19. Phase/currents unbalanced or too high.
20. Insulation between phases and earth ground, <1M-ohm.
21. Density of the pumping media too high.
22. Defective level sensor.
23. Hand/Off/Auto switch not in Auto Position.
24. Defective H/O/A switch, relay or contactor coil.
25. Air Captured in Cooling Jacket.
26. Pump not properly seated on Auto Coupling.
27. Water intrusion through junction box.
28. Run capacitor size too large.
29. Start capacitor size too small.
30. Profile seal not sealing or missing.
31. VFD or Soft Start not functioning properly.
32. Start Relay or Capacitors damaged. (1 ph)

If you need additional help, please contact your local distributor or e-mail service@homapump.com

PREVENTIVE MAINTENANCE

Regular preventive maintenance will help ensure longer pump life and more reliable operation. It is recommended that pumps in intermittent operation be inspected twice a year and pumps in continuous operation be inspected every 1,000 hours. The following is a listing of required inspection and maintenance items.

If any of the problems described in the following list exists stop operating the pump to avoid damage or personal injury.

1. CABLE ENTRY

Make sure that the cable entry flange and strain relief clamp are tight. If the cable entry is showing signs of leakage remove cable from entry, remove grommet, cut a piece of cable off so that the grommet seats on a new portion of the cable, replace grommet, and reinstall cable assembly, into the top of the motor.

Note: Explosion Proof cables are sealed with a Factory Mutual Approved potting compound. Please consult factory for instruction.

2. CABLES

Inspect the cable for cuts, scrapes or sharp bends. If the outer jacket is damaged, replace the cable. Do not attempt splices within wet wells.

3. MOTOR INSULATION RESISTANCE

Megger the insulation between the phases and between any phase and ground. Resistance values should be greater than 1 M ohm. If abnormal readings are obtained contact authorized service center immediately.

4. EXTERNAL PARTS ON PUMP

Make sure that all screws, bolts and nuts are tight. Check the condition of pump lifting eyes and replace if damaged or worn, Replace any external part that appears worn or damaged.

5. SEAL CHAMBER OIL

Caution seal chamber may be pressurized

Check the condition of the oil to see if any water leakage has occurred. Lay the pump on its side with the plug facing upward and remove the oil fill plug. Drain the oil from the seal chamber into a transparent container. Check for impurities and emulsification (Oil is cream-like). If water intrusion has occurred check lower mechanical seal and replace if necessary. Refill seal chamber with fresh oil. Refer to shop manual for type and quantity of oil.

6. IMPELLER

Periodically inspect impeller by turning pump on its side, remove suction strainer nuts and strainer to expose impeller and relocate position of adjusting plate (suction cover) as needed. Replace the impeller if it is damaged or severely worn.

7. PROFILE SEAL

When pump is removed for any service, carefully inspect the profile seal for signs of damage or improper sealing. Be sure the contact patch is fully around the seal face.

SPARE PARTS

In order to obtain spare parts identify the required parts by looking at the appropriate cross sectional drawing and listing, and contact authorized HOMA PUMP TECHNOLOGY representative with the parts required and the pump serial number. Authentic Homa Pump Technology parts shall be used to maintain warranty.

Note: Explosion Proof pumps must be identified as such, and the pump serial number must be referenced for proper parts identification.

RECOMMENDED TOOLS AND SUPPLIES

In addition to ordinary, standard tools and lifting devices, ensure that complete set of metric Allen wrenches, dead blow hammer, impeller puller, Loctite 242 (Blue), petroleum jelly and anti-seize compound are on hand.

PROFILE SEAL INSTALLATION

IMPORTANT

Black Rubber Sealing Ring (Profile Seal) must be installed in the Guide Claw before pump is installed. Ring must be installed with the large diameter lip inside the groove of the Guide Claw Flange.

Correct

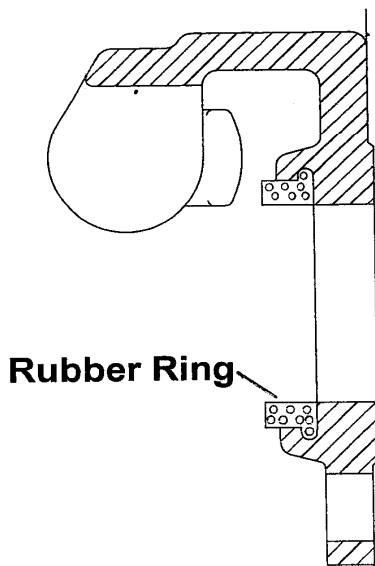

Incorrect

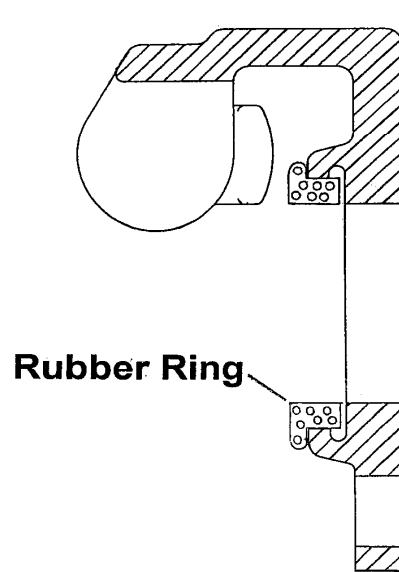

CALL OUR TECHNICAL GROUP WITH ANY QUESTIONS REGARDING THE INSTALLATION OF THIS EQUIPMENT.

SEAL PROBE INSTALLATION PROCEDURE

Mechanical Seal Leak Detection probe has been loose to protect from shipping damage. Please follow this procedure to install the probe.

- 1) Lay pump on its side with the plug on the seal chamber facing upwards as indicated.
- 2) Unscrew the plug with the proper wrench, taking care not to damage the sealing surface.
- 3) Verify that seal chamber oil level is within $\frac{1}{4}$ " of the indicated value. Measurement is from oil level to the top of hole. See IOM Manual for seal chamber oil volume, if required.
- 4) Remove the new sealing gasket from package and install it onto the seal probe plug.
- 5) Install the seal probe with gasket into the opening, taking care not to damage the cable. Then tighten the seal probe with the proper wrench until snug. Do not overtighten. Once tight, verify the seal gasket is properly seated and the cable is not pinched or twisted.
NOTE: At installation of the seal probe be careful not to bind the seal probe cord as it is being installed into the pump.
- 6) Lift pump into a vertical position and inspect for any leaks.
- 7) Secure seal probe cable to pump body and power cable with tyrap before installing pump.

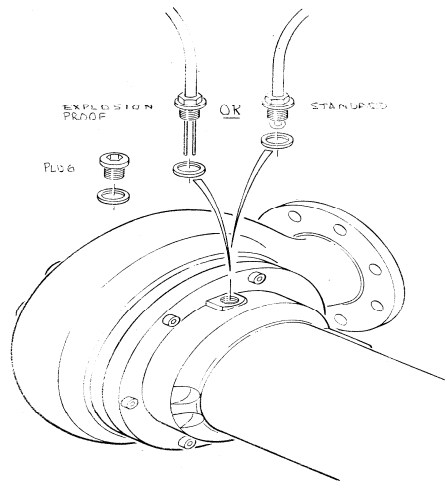

External Seal Probe Connections

Single Wire Option

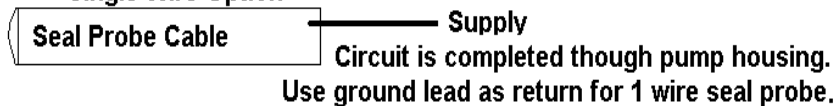

Two Wire Option

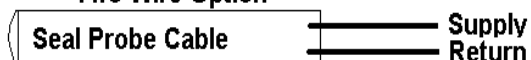

GRP 10 to 79 Series Single Phase Pump Connection Diagram Start & Run Capacitor w/ Relay

Note: If wire numbers or markers are different than shown, consult factory!

HOMA single phase pumps require that start and run capacitors be installed with a potential relay in the start winding. Use the diagrams below to identify the correct method of wiring.

Note: GRP 10/16/21 (except XP) pumps have internally wired thermal switches. These pumps use 4 conductor cable.

Wire **Z2** is the connection to the start winding.
Wire **U2** is the connection to the run winding.
Wire **U1** is the common connection for both windings.



Ground Lug - For auxiliary
grounding to earth or grounding grid.

4 Conductor Cable



6 Conductor Cable

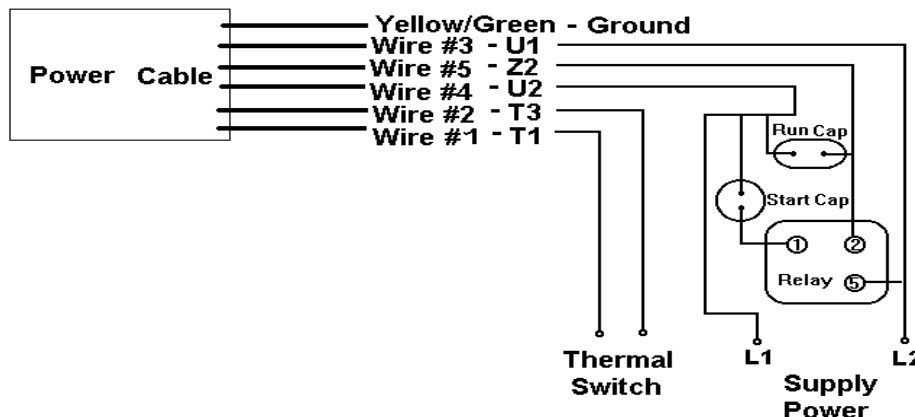

GRP 10 to 79 Series Single Phase Pump Connection Diagram Start & Run Capacitor w/ Relay

Note: If wire numbers or markers are different than shown, consult factory!

Wire **Z2** is the connection to the start winding.
 Wire **U2** is the connection to the run winding.
 Wire **U1** is the common connection for both windings.

7 Conductor Cable

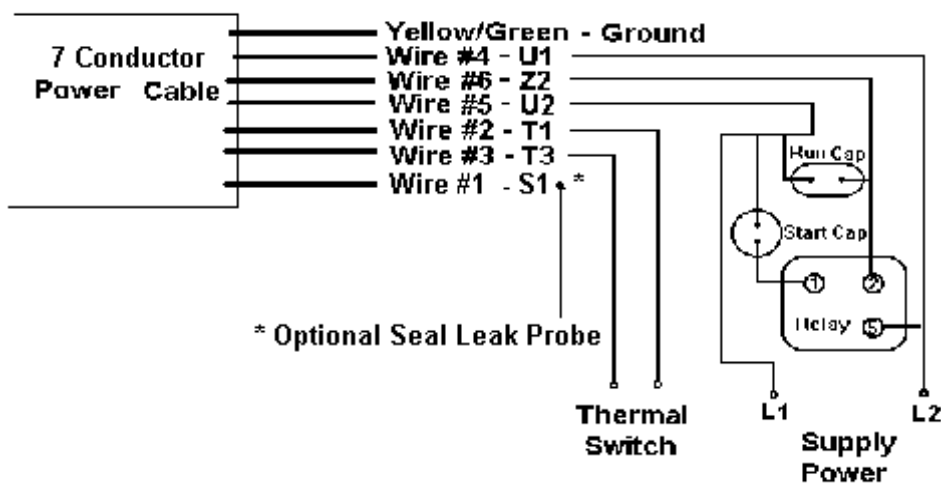

10 Conductor Cable

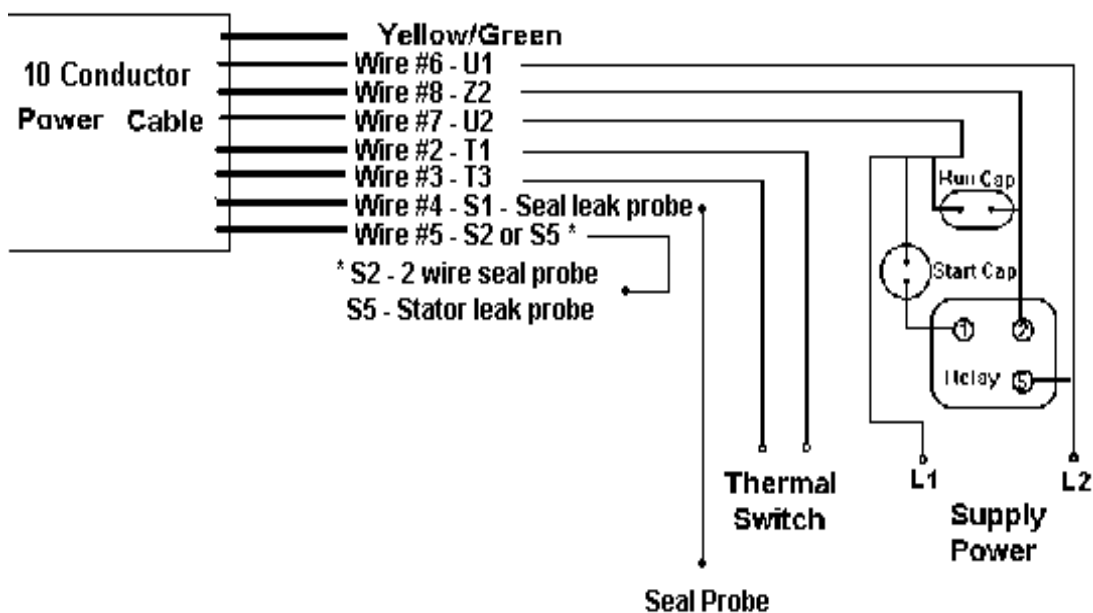

Capacitor Sizing Chart

GRP 10 to 21/1	25 uf @ 370V Run Capacitor -	50 uf @ 330V Start Capacitor-PN#:8857005
GRP 26/1	40 uf @ 370V Run Capacitor -	80 uf @ 330V Start Capacitor-PN#:8857010
GRP 28 - 41/1	50 uf @ 370V Run Capacitor -	150 uf @ 330V Start Capacitor-PN#:8857015
GRP44/1	70uf @ 330V Run Capacitor -	320 uf @ 330V Start Capacitor- PN#8857084
GRP 58/1	120 uf @ 370V Run Capacitor -	200 uf @ 330V Start Capacitor-PN#:8857025
GRP 78/1	120 uf @ 370V Run Capacitor -	300 uf @ 330V Start Capacitor-PN#:8857030
GRP 59/1	100 uf @ 370V Run Capacitor -	350 uf @ 330V Start Capacitor-PN#:8857085
GRP 79/1	120 uf @ 370V Run Capacitor -	350 uf @ 330V Start Capacitor-PN#:8857090

7.5 HP and larger motors require multiple run and start capacitors to achieve the necessary capacitance value. Refer to the capacitor wiring diagram supplied with each capacitor kit.

Note: See 3 Phase Connection Diagram for Seal Probe wiring.

Single Phase Pump Start-Up Procedure

Run Capacitor sizing can vary depending on the incoming supply voltage provided. HOMA Single Phase pumps are provided with Start and Run Capacitor(s) sized for 220-230V under load. Frequently, the available line voltage is considerable different than indicated, and the Run capacitor(s) may need to be resized to match the available field voltage. The following procedure will allow you to verify proper operation of your single phase pump, and/or make necessary changes to you capacitors to correct for your power supply.

After verifying wiring is in accordance with your pump requirements, start pump and record the following readings from each of the (3) pump cable leads.

Current under load:

U1 _____ Amps, > U2 _____ Amps, > Z2 _____ Amps
 Should be (highest reading) (middle reading) (lowest reading)

Lead U1 (common) should have the highest current reading. Lead Z2 (start) should have the lowest reading.

If Z2 current draw is greater than the current draw of either U1 or U2, a smaller size Run capacitor (lower microfarad rating) is required to correct the condition. Example: If a 60 uf Run capacitor was supplied, change to a 50 uf Run capacitor and check current readings. Typically, only one step down in capacitor size is required, but in certain instances 2 steps may be required.

() The standard capacitor kit provided includes: _____ uf start capacitor
 _____ uf run capacitor

() Additional run capacitors have been included for use in tuning the pump to match available line voltages for optimum performance.

_____ uf run capacitor
 _____ uf run capacitor
 _____ uf run capacitor

This form is provided for your use in optimizing the performance and service life of your single phase pumps, and is applicable to most Capacitor Start and Run motors. Please contact our Technical Service Dept. @ 800-452-4662 with any questions or if you require any additional information or assistance.

GRP Series Three Phase Connection Diagram



Note: GRP 10 -21 (except XP) pumps have internally connected thermal switches. These pumps use (1) 4 conductor cable.

Ground Lug - For auxiliary grounding to earth or grounding grid.

Multiple Cable Configuration Your pump may have 1, 2 or all 3 of these cables.
Cables are to be connected as indicated, with multiple conductors paired together.

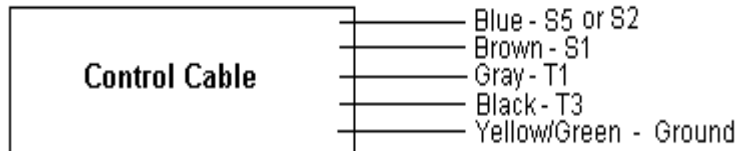
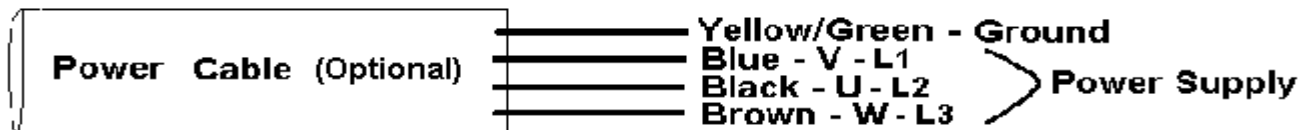

Note: S2 - Seal Probe (2 wire)
S5 - Stator Leakage Probe

7 Conductor Cable



10 Conductor Cable

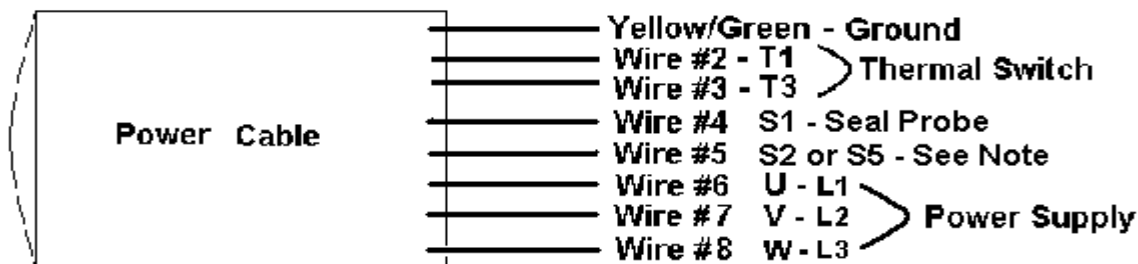

Note: S2 - Seal Probe (2 wire)
S5 - Stator Leakage Probe

Note: Wire Colors are usually consistent, but wire numbers should be used if a conflict exists.

GRP Series Three Phase Connection Diagram T Motors

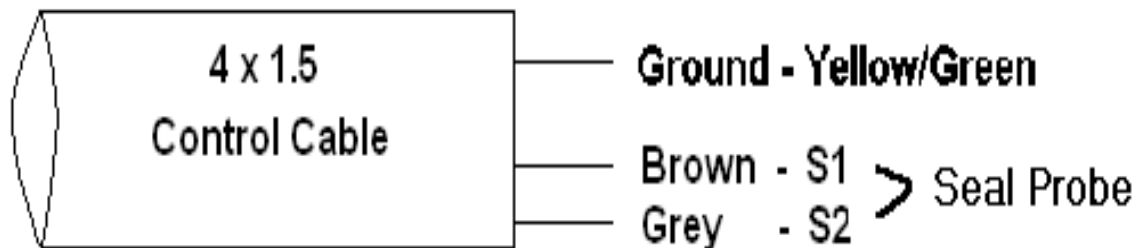
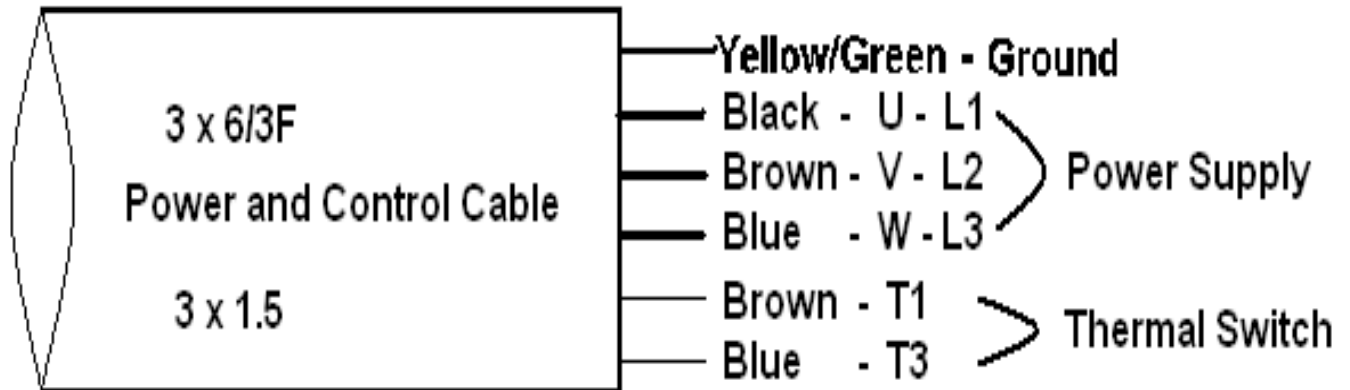

START-UP REPORT

This report is designed to insure the customer that customer service and a quality product are the number one priority with HOMA Pump Technology, Inc. Please answer the following questions completely and as accurately as possible. Mail this form to:

**HOMA PUMP TECHNOLOGY INC.
390 BIRMINGHAM BOULEVARD
ANSONIA, CT 06401
ATTN: SERVICE MANAGER**

**Receipt of completed report will initiate operational warranty.
Reports that are not returned can delay or void warranty.**

- 1.) Pump User's Name: _____
Site Location: _____
Site Contract: _____
Unit Supplied By: _____

- 2.) HOMA Pumps Model _____ Serial No. _____
Voltage _____ Phase _____ Hertz _____ Horsepower _____
Method Used to Check Rotation (viewed from bottom) _____
Does Impeller Turn Freely By Hand: YES _____ NO _____

- 3.) Condition of Equipment: EXCELLENT _____ GOOD _____ AVERAGE _____
Condition of Cable Jacket : EXCELLENT _____ GOOD _____ AVERAGE _____
Resistance of Cable and Pump Motor (measured at pump control)
1 Phase: U1 – U2 _____ Ohms; U1 - Z2 _____ Ohms; U2 – Z2 _____ Ohms; T1 – T2 _____ Ohms
3 Phase: U - V _____ Ohms; V - W _____ Ohms; U -W _____ Ohms, T1 – T2 _____ Ohms

Resistance of Ground Circuit Between Control Panel and Outside of Pump _____ Ohms
MEG Ohm Check of Insulation:
U to Ground _____ V to Ground _____ W to Ground _____

- 4.) Condition of Equipment at Start-Up: Dry _____ Wet _____ Muddy _____
Was Equipment Stored: _____ Length of Storage _____
Describe Station Layout _____

- 5.) Liquid Level Controls: Model _____ Type _____
Is Control Installed Away From Turbulence? _____
Operation Check: (IF FLOAT SWITCHES SUPPLIED).
Tip lowest float (stop float), all pumps should remain off.
Tip second float (and stop float), one pump comes on.
Tip third float (and stop float), both pumps on (alarm on simplex).
Tip fourth float (and stop float), high level alarm on (omit on simplex).

- 6.) Electrical Readings:
Single Phase:
Voltage Supply at Panel Line Connection, **Pump Off**, L1, L2 _____ L1-Ground _____ L2-Ground _____
Voltage Supply at Panel Line Connection, **Pump On**, L1, L2 _____ L1-Ground _____ L2-Ground _____
Amperage: Load Connection, **Pump On**, U1 _____ U2 _____ Z2 _____
Resistance Across Thermal Switch leads T1-T2 _____ ohms

Three Phase:
Voltage Supply at Panel Line Connection, **Pump Off**, L1-L2 _____ L2-L3 _____ L3-L1 _____
Voltage Supply at Panel Line Connection, **Pump On**, L1-L2 _____ L2-L3 _____ L3-L1 _____
Amperage Load Connection, **Pump On**, L1 _____ L2 _____ L3 _____
Resistance Across Thermal Switch leads T1-T2 _____ ohms

7.) Final Check:

Are Thermal Switches properly wired? What Over-temperature Relay is being used? _____

Is Pump Seated On Discharge Properly? _____ Check For Leaks? _____

Does Check Valves Operate Properly? _____

Flow: Does Station Appear To Operate At Proper Rate _____

Vibration Level: Measured _____ Observed _____

COMMENTS: _____

8.) Equipment Difficulties During Start-Up: _____

9.) I Certify this Report to be accurate.

Authorized Homa Service Representative:

_____ Phone # _____

(Signature)

DATE _____

Pump Station Owner/ Operator

_____ Phone # _____

(Signature)

DATE _____

GRP Technical Details

The following is offered as a general guide to values and capacities commonly used.

	Resistance Readings (ohms)				Pump Weight Approx. (Lbs.)
	230V		230V	460V	
	1 Phase		3 Phase *	3 Phase *	
	U1 - U2 / U1 - Z2	U-V-W	U-V-W		
GRP 10 to 21	2.0u	6.0u	3.0u	9.7u	65#
GRP 24/26	1.9u	3.6u	2.0u	7.3u	88#
GRP 28/34/36/41	0.9u	2.3u	1.4u	3.8u	100#
GRP 44					
GRP 58/59	0.5u	0.7u	0.5u	1.6u	230#
GRP 78/79	0.3u	0.5u	0.5u	1.6u	239#
GRP117/118	N/A		0.3u	0.9u	248#

*Values should be as indicated between any 2 power leads.

Note: Resistance values include 30' cable, and should be within +/- 10% of above value.

Impeller Bolt Torque 12 Ft. #

Impeller to Bottom Plate Clearance .010" or 1/4 turn of adjuster screws

Pump Rotation Right hand (CW) looking down from top of motor. CCW looking at cutter blade.

Seal Probes GRP pumps use a 12mm seal probe. Single wire probes are for non classified areas, and 2 wire probes are for Hazardous areas.

Seal Chamber Oil - White Mineral Oil (Chevron Lubricating Oil FM 32, 46, 68)

Seal Oil Volume

GRP 10, 12, 16, 19, 21	.72L
GRP 24, 26, 28, 34, 36, 37, 41	1.0L
GRP 58, 78, 117	2.5L
GRP 59, 79, 118	1.90L

Minimum Distance between 2 pumps

GRP 10, 12, 16, 19, 21	6"
GRP 24, 26, 28, 34, 36, 37, 41	6"
GRP 58, 78, 117	8"
GRP 59, 79, 118	8"

Seal Oil Level

With pump lying on its side and oil port at 12:00, measure from the top of housing with gasket in place, to the oil level.

GRP 10 to 41	1" from top of housing to oil level
GRP 58/59 to 117/118	1 1/2" from top of housing to oil level