

A Series

Installation, Operation & Maintenance Manual

Project: _____

Installation: _____

Pump Model: _____ **Serial Number:** _____

AIOM REV. 2/11

HOMA Pump Technology, Inc.
390 Birmingham Boulevard • Ansonia, CT 06401

A Series

GENERAL INSTRUCTIONS:

This manual is intended to provide basic installation and start-up guidance. It is to be read and thoroughly studied prior to attempting to install or operate any of the equipment supplied. *Equipment damage, which occurs by not following these instructions will void the warranty.*

SAFETY PRECAUTIONS:

Only trained qualified personnel shall be utilized for installation and start-up.

The following is a general list of safety precautions that should be followed when installation starting-up or servicing the pump.

The pump station owner or operator is ultimately responsible for ensuring that all equipment is installed, started up and operated in a safe manner.

- Do not work alone.
- Double check to make sure that all lifting equipment is in good working order and that it has adequate lifting capacity for the weight that it will handle.
- Wear safety helmet, goggles and protective shoes, or appropriate safety materials required.
- Before working on the pump make sure that the power is disconnected and cannot be energized by others. Lockout and tag the control panel circuit breaker.
- Do not stand under suspended loads!
- Never enter or work within a wet well without first checking to make sure sufficient oxygen is present and that there are no explosive or poisonous gases present.
- All personnel, who work with sewage pumping equipment and systems shall be vaccinated against diseases that can occur. If there are any questions or doubts in this area it is strongly suggested that the local health agency be contacted.
- For Hazardous Area Classifications, only use pumps with suitable Explosion Proof Rating.

EQUIPMENT INVENTORY AND INSPECTION:

Upon arrival of pump shipment carefully unpack all components and compare with shipping and purchase order documents to ensure that the order is complete. Also inspect equipment for any damage that might have occurred in shipment. *If any problems are detected contact an authorized HOMA Pump Technology Representative immediately.*

TRANSPORTATION AND STORAGE PROCEDURE:

Always lift the pump by its lifting bail or eye bolt. **Never lift the pump by its power cable! Jacketed pump should never stored or shipped with the pump by the jacket. Damage to Sealing O ring may result.**

Pumps should be stored in an upright position, taking extreme care to protect the power cable and control cables from crushing, nicks or tears which would permit water intrusion. Power cable ends must be protected from immersion in water as well as moisture intrusion. The cable will wick water into the pump if it is not protected properly. Power cable leads should be covered with shrink tubing or suitable sealing material during storage.

Short Term Storage: Short term storage is defined as any time less than six months. We recommend that pump and accessories be stored in its original shipping container in a dry, temperature controlled area. If climate controlled storage is not possible, all exposed parts should be inspected before storage and all surfaces that have the paint scratched, damaged or worn should be re-coated with air dry enamel paint. The pump should be stored in an upright position.

Long Term Storage: Any storage time exceeding six months is considered long term. In addition to the safeguards specified above, the impeller should be rotated once a month to prevent the mechanical seals from being damaged, and the pump should be inspected. The seal chamber oil should be drained and replaced prior to commissioning. The pump should be stored in an upright position.

A Series

ELECTRICAL INSTALLATION:

GENERAL GUIDELINES

All electrical work shall be carried out under the supervision of an authorized, licensed electrician. **The present state adopted edition of the National Electrical Code as well as all local codes and regulations shall be complied with.**

VERIFICATION OF POWER SUPPLY

Prior to making any electrical connections or applying power to the pump, compare the power supply available at the pump station to the data on the unit's nameplate. *Confirm that both voltage and phase match between pump and control panel.* The voltage supplied at the pump shall be +5 / -10% of the nameplate value, frequency shall be + / - 1% of the nameplate value, the voltage phase balance shall be within 1% and the maximum corrected power factor shall be 1.0.

POWER LEAD WIRING

HOMA A Series pumps may be provided with 1 or more cables, depending on motor horsepower and operating voltage. Power leads L1, L2, & L3 may be provided as single conductor, or as multiple conductors. Multiple conductor configurations may use leads from separate cables, or may use two conductors within one cable. Please refer to wiring diagram in the appendix for specific connection details. *The pump must be connected electrically through a motor starter with proper circuit breaker protection in order to validate warranty. Do not splice cables.*

THERMAL SWITCH WIRING :

Pumps are equipped with thermal switches embedded in the stator windings which are normally closed, automatically resetting switches. Switches will open when the internal temperature rises above the design temperature, and will close when the temperature returns to normal. Thermal switches must be wired to a current regulated control circuit in accordance with the NEC.

Identify thermal switch leads marked T1 and T3 in the power or control cable.

The resistance across the leads will be .5 Ohms. Thermal leads must be connected to the thermal overload relay located in the control panel.

Thermal switch leads must be connected to validate warranty.

Note: All sizes of Class 1, Div. 1 pumps for hazardous service must have thermal switch leads connected to a current regulated control circuit in accordance with NEC.

SEAL PROBE WIRING

The mechanical seal leak detector probe utilized in the pump is a conductive probe which is normally open. The intrusion of water into the seal chamber completes the electrical circuit. Control panel provisions will sense this circuit closure, and will provide indication or alarm functions depending on the panel design.

Either single or dual wire systems may be provided. Single wire systems utilize one energizing conductor, and the pump casing and neutral lead as the ground or return portion of the circuit. The dual wire systems utilize two separate conductors for each leg of the circuit. With either system, the seal probe leads must be wired into a control circuit provided in the control panel. This control circuit must energize the probe with a regulated power source, and sense the closed circuit in event of water intrusion. Indication and alarm functions must also be provided in the control circuit. Please see control panel wiring diagram for seal probe connection points. **IMPORTANT: For Hazardous Area Classification Pumps, leak detector circuit must be in conformance with applicable NEC codes and regulations.**

START / RUN CAPACITORS AND RELAYS:

All single phase motors require start and run capacitors along with a start relay to operate. Refer to the wiring diagram in the appendix. Capacitors and relays must be sized for the specific motor.

Capacitors are sized based on ideal conditions. The run capacitor may need to be resized to match the available field voltage. Each cap kit shipped is supplied with a wiring diagram and start up procedure.

A Series

Variable Frequency Drives:

Special considerations must be taken when operating pumps with variable frequency drives (inverters). *The inverter circuit design, horsepower required by pump, motor cooling system, power cable length, operating voltage, and anticipated turndown ratio must be fully evaluated during the design stage of the installation.*

As a minimum, properly sized load reactors and filters must be installed between the inverter and the pump to protect the pump motor from damaging voltage spikes.

Warranty coverage will not be provided on any pump motor that is operated with a variable frequency drive, unless the load side of the inverter is properly isolated from the pump.

ADDITIONAL PUMP PROTECTIVE DEVICES

Several optional pump protection devices are available to protect submersible motors from damage, and may have provided in you pump.

Temperature Sensing RTD*: PT100 sensors are available in two critical locations on larger machines, the lower bearings and motor windings. N.C. Circuit - 108 ohm

Moisture Sensors: Two styles of moisture sensors are available on HOMA pumps.

Moisture Detectors*: These are micro float switches designed to detect small amounts of liquid. These are available in the stator housing of 50hp and larger size pumps. N.C. Circuit - 268 ohm

Leakage Detectors*: These Normally Open, single or 2 wire probes are used to detect the presence of water in the pump. *Single wire probes use the pump ground to complete circuit.* Optional leak detectors can be installed as follows:

Stator Chamber installation: Probe placed in bottom of stator housing to detect presence of water in the chamber.

Stator or Motor cap installation: Probe used to detect the presence of water only into the stator housing or motor cap terminal board.

Closed loop cooling Installation: Probe placed in stator housing to detect the presence of liquid in the dry chamber.

* HOMA Go Switch or approved equivalent relay is required for sensor operation.

MECHANICAL INSTALLATION: PUMPS WITH AUTOCOUPLING SYSTEMS

The HOMA Auto-Coupling is a quick removal system used in keeping personnel from having to enter the wet well. The pump mounts on a stationary base and operates completely or partially submerged (minimum 10" over volute) in the pumping media.

The HOMA Auto-Coupling kit consists of a base, guide claw flange, upper guide rail bracket, profile seal and base anchor bolts. Refer to dimensional drawing for details.

For all A Series pumps, attach the guide claw flange to the pump discharge flange with the fasteners and gaskets included with the auto-coupling kit. Use tightening torque's indicated in the table on pg. 5. Do not over tighten! Install the profile gasket (if not already installed at the factory) into the guide claw with the large diameter fitted into the groove inside the claw. Refer to the diagram included with the auto-coupling kit for proper profile gasket installation.

Install suitable lifting chain of an adequate size and length to permit proper lowering and raising of the pump.

Properly locate the base and with the anchor bolts fasten to the floor of the pump station. Make sure when locating and securing the anchor bolts that the base will align properly with the access cover at the top elevation of the station (Refer to outline drawing in appendix). Place the base in position, and level the base.

A Series

If the base is not level, proper sealing of the pump to base may not occur!

Place the guide rails (supplied by others), cut to length in to the rings of the base. The rails will be secured at the top of the pump station with the upper guide bar bracket and to extend down to the sump floor.

Install the upper guide bar bracket as shown in the appendix.

For stations exceeding 10 feet in depth intermediate guide bar brackets are recommended. One bracket is recommended for each additional 10 feet of station depth.

Check that the guide system is properly installed in the vertical orientation by using levels and a plumb line. Fully tighten all anchors and mounting bolts.

Connect the station riser piping to the outlet flange of the base.

Before lowering the pump, verify the direction of impeller rotation (refer to start-up section for procedure).

Make sure to use lifting equipment that has adequate capacity for the pump that will be handled. Before installing pump, check to be certain the profile seal (rubber ring) is properly positioned in the guide claw flange. Then position pump so the guides on the discharge flange engage the rails. Slowly lower the pump along the guide rail. Once the pump reaches its bottom location it will automatically connect to the base.

It is recommended that the stationary base elbow be visible before lowering the unit. If this is not possible, ensure all debris is removed from wet well.

Important: Do not install more than one (1) check valve into any piping system or problems will occur.

INSTALLATION OF PUMPS WITH RING STANDS:

The ring stand design allows for a free standing, simple economical installation or to be transportable from one installation to another. It is intended to operate completely or partially submerged in the pumping liquid.

Install the ring stand to the underside of the volute with the supplied fasteners provided. Apply thread locking compound such as blue #242 and tighten the bolts using the torque table indicated in the table. Do not over tighten! Install suitable lifting devise of an adequate length to ensure proper lowering and raising capabilities. Lower the pump into the area where it is required. Properly position power cable and chain so they stay above pump and cannot enter the pump suction.

INSTALLATION OF PUMPS FOR DRY PIT APPLICATIONS:

Foundation and Piping Requirements:

General

The following recommendations are basic guidelines which are intended to outline basic requirements in the design of the dry pit station. It is essential that a licensed professional engineer be retained by the owner to design the station and all support structures.

Foundations

Foundations may consist of any structure heavy enough to provide permanent rigid support for the pump and inlet elbow stand. Concrete foundations built up from the solid ground are the most commonly used. The concrete floor shall be level. The space required by the inlet stand and the location of the foundation anchor bolts are shown on the outline dimension drawing. Foundation bolts are to be embedded in the concrete.

A Series

Suction Piping

Suction piping should be at least as large as the pump inlet elbow suction. If reducers are utilized they should be of the conical type. If the liquid source level is below the volute horizontal centerline, the reducer must be eccentric and installed with the level side up. If the liquid level is above the pump volute horizontal centerline, either eccentric or concentric reducers may be used. Suction piping should be run as straight as possible. All pipe flange joints should be gasketed to prevent air from entering the pipe. High points that may collect vapor are to be avoided. Isolation valves such as gate valves can be installed in order to facilitate the removal of the pump for maintenance. Any valve installed in the suction line should be installed with the stems horizontal.

Discharge Piping

A check valve and isolation valve shall be installed in the discharge line. The check valve should be installed between the pump discharge flange and the isolation valve. If pipe increasers are used on the discharge line, they should be placed between the check valve and the pump. The inlet elbow stand allows the pump to be installed in a stationary position in a dry pit. Place the inlet stand in position and tighten the anchor nuts.

Lower the pump on to the top flange of the inlet stand. **DO NOT ALLOW SLACK ON THE LIFTING CABLE UNTIL THE PUMP IS BOLTED DOWN.** Make sure the flange bolt holes align with the mounting holes on the underside of the volute. Secure the pump to the mounting flange with the fasteners that are specified in the accessory fastener selection table below.

PUMP MODEL	Bolts Anchors	SIZE	TORQUE
3" A SERIES AUTOCOUPLING	8 4	M16X60mm M16	108 ft/ # 74 ft/ #
4" A-SERIES AUTOCOUPLING	8 4	M16X60mm M16	108 ft/ # 74 ft/ #
3" & 4" A-SERIES RING STAND	4	M16x25mm	108 ft/#
3" & 4" A- SERIES DRY SUMP	8 4	M16x40mm M16	108 ft/# 74 ft/#
6" A-SERIES AUTOCOUPLING	8 4	M20x70mm M16	150 ft/# 74 ft/#
6" A-SERIES RING STAND	4	M20x40mm	150 ft/#
6" A-SERIES DRY SUMP (1 Piece)	8 4	M20x45mm M16	150 ft/# 74 ft/#
6" A-SERIES DRY SUMP (N/PMotor)	8 4	M20x65mm M16	150 ft/# 74 ft/#
6" A-SERIES DRY SUMP (F Motor)	8 4	M20x70mm M16	150 ft/# 74 ft/#
8" A-SERIES AUTOCOUPLING	8 4	M20x70mm M20	150 ft/# 150 ft/#
8" A-SERIES RING STAND	4	M20x30mm	150 ft/#
8" A-SERIES DRY SUMP (2 Piece)	8 4	M20x75mm M20	150 ft/# 150 ft/#

Notes:

1. For pumps larger than 8" please consult factory.
2. Flange bolts must be tightened in cross pattern to avoid damage to the raise face flanges.
3. Standard Flange Bolts are 316SS
4. Standard Anchors are Plated Steel
5. Autocoupling systems include qty 4 M12 anchors for the upper bracket. Torque to 38 ft#.
6. Anchor bolt holes should be drilled to the actual diameter of the anchor (M12 anchor requires 12mm diameter hole).

A Series

Jacketed Pump Option

The cooling jacket has been supplied based upon the specified operating conditions of this application. It is important this jacket is function properly, or the internal motor components could become damaged.

Several cooling configurations are available depending upon customer preference and system requirements. You must know what configuration of cooling system is to be used with the pump prior to installation. In some cases, field test results may indicate a change of cooling method is required. Consult factory for necessary changes to the pump.

Cooling Requirements

1 - Standard Media Cooled – This construction does not require any external piping and it is completely self-contained. This design is suitable for the routine collection system application. No pump modifications are required.

Required Hardware – Automatic air bleed valve mounted in upper vent port or a 1/4" or 3/8" elbow and small block valve for venting. A length of hose routed to the sump should be attached to either air bleed or the block valve outlet.

Start Up Requirements – This jacket must be vented at start up. Additional venting may be required after situations where the suction or discharge piping has been removed for maintenance and reinstalled. Some adverse operating conditions can allow air to become trapped in this jacket. This must be periodically vented off. If this occurs, it is recommended the small air bleed valve is utilized.

2 - Media Cooled with External Flush - This construction requires an external flow of water, typically re-use water. Applications which require this option are typically heavy slurry or sludge service often found in the treatment plant. This option routes the externally supplied water into the pumped media. No pump modifications are required.

Required Hardware – Mounting a regulating valve, pressure gauge and automated block valve between the water supply and the upper jacket port is required. The supply valve should be adjusted to allow the supply of water to exceed pump discharge pressure. This assures a positive flow of water into the pump chamber. The block valve should be automated to open whenever the pump is operated.

Start Up Requirements – This jacket must be vented at start up. Additional venting may be required if cooling water supply is interrupted.

3 - External Fluid Cooled - This option requires an external flow of water like in option 2 above, but is used where dilution of the pumped product is not desirable. The supply of water is internally isolated from the pumped media. The water inlet is routed into the jacket's lowest port and returned out of the highest port. This option does NOT allow water to enter the pumped media and pump must be ordered from factory this way.

Required Hardware – Mounting a regulating valve, pressure gauge and automated block valve between the water supply and the upper jacket port is required. The supply valve should be adjusted to allow for a good supply of water to flow through the jacket. The block valve should be automated to open whenever the pump is operated.

Start Up Requirements – This jacket must be vented at start up. Additional venting should not be required.

Vent Valve Installation

HOMA dry pit pumps are supplied with a valve and fitting that must be installed and maintained to ensure the proper performance of these pumps.

The opening for this valve is located on the base of the motor cap near the mounting screws. The pump is shipped with a plug installed which must be removed prior to start up.

This opening is a metric straight thread and requires an adapter included with the valve and fitting hardware. It is also recommended that a length of hose be attached to the valve and routed back to the sump.

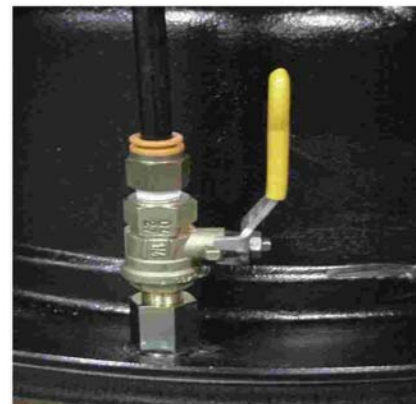

Note: Leave vent valve open in wet pit pump application to prevent air entrapment in jacket.

A Series

Installation / Startup Troubleshooting:

Only authorized service personnel who are trained professionals shall troubleshoot and repair pumps that are experiencing operational or performance difficulties.

All HOMA pumps are factory tested, yet startup difficulties can occur with any mechanical equipment. Please note that our technical support staff stands ready to assist you with any problem or difficulty you might encounter with our equipment.

The following is a tabulation of common start-up problems and possible causes.

Symptom

Possible Causes

Pump will not start

1, 2, 3, 4, 27, 28, 29, 31, 32

Little or zero discharge

5, 6, 7, 8, 16, 30, 32

Insufficient discharge flow/pressure

5, 6, 9, 10, 11, 12, 26, 30

Excessive power consumption

6, 9, 13, 28, 30

Excessive current draw

6, 13, 14, 15, 19, 26, 30

Excessive pump vibration/noise

12, 15, 16, 25, 26, 28, 31

Pumps runs & motor protection trips

17, 18, 19, 20, 21, 28

Pumps runs manually, but not automatically

22, 23, 24

Pump runs hot

7, 19, 25, 26, 28

Listing of Possible Causes:

1. Incorrect or no power supplied to motor.
2. Power cable cut.
3. Short to ground in cable or motor winding.
4. Control panel circuit breaker open.
5. Actual system head is higher than calculated or specified.
6. Incorrect impeller rotation direction.
7. Sump liquid level is below pump's minimum submergence requirement.
8. Closed discharge valve or jammed check valve.
9. Wear ring (s) worn. (If Applicable).
10. Vortex at pump's suction.
11. Discharge valve partially closed.
12. Insufficient NPSHA (Dry Pit Application).
13. Actual system head is lower than specified resulting in over pumping condition.
14. Voltage supply to motor is lower than required by motor.
15. Damaged bearings.
16. High system head causing pump to operate at extremely reduced capacity.
17. Object stuck inside impeller.
18. Motor not receiving proper voltage on all three phases.
19. Phase/currents unbalanced or too high.
20. Insulation between phases and earth ground, <1M-ohm.
21. Density of the pumping media too high.
22. Defective level sensor.
23. Hand/Off/Auto switch not in Auto Position.
24. Defective H/O/A switch, relay or contactor coil.
25. Air Captured in Cooling Jacket.
26. Pump not properly seated on Auto Coupling.
27. Water intrusion through junction box.
28. VFD or Soft Start not functioning properly.
29. Run capacitor size too large (1ph).
30. Start capacitor size too small (1ph).
31. Profile seal not sealing or missing.
32. Start relay or capacitor damaged (1ph).

Please note that some possible causes may not relate to your particular model.

If you need additional help, please contact your local distributor or e-mail service@homapump.com

A Series

MAINTENANCE

Regular maintenance will help ensure longer pump life and more reliable operation. It is recommended that pumps in intermittent operation be inspected twice a year and pumps in continuous operation be inspected every 1,000 hours. The following is a listing of required inspection and maintenance items.

If any of the problems described in the following list exists stop operating the pump to avoid damage or personal injury.

1. CABLE ENTRY

Make sure that the cable entry flange and strain relief clamp are tight. If the cable entry is showing signs of leakage remove cable from entry, remove grommet, cut a piece of cable off so that the grommet seats on a new portion of the cable, replace grommet, and reinstall cable assembly, into the top of the motor.

Note: Explosion Proof cables are sealed with a Factory Mutual Approved potting compound. Please consult factory for instruction.

2. CABLES

Inspect the cable for cuts, scrapes or sharp bends. If the outer jacket is damaged, replace the cable. Splices of the power or control cable within the wet well area are not acceptable.

3. MOTOR INSULATION RESISTANCE

Megger the insulation between the phases; and between any phase and ground. Resistance values should be greater than 1 M ohm. If abnormal readings are obtained, contact authorized service center immediately.

4. EXTERNAL PARTS ON PUMP

Make sure that all screws, bolts and nuts are tight. Check the condition of pump lifting eyes and replace if damaged or worn, Replace any external part that appears worn or damaged.

5. SEAL CHAMBER OIL

Note: Use extreme care when removing the seal chamber plug, as the chamber may become pressurized if seal failure has occurred. Seal chamber oil should be checked for signs of water intrusion, or other impurities any time the pump is removed from wet well. To check the condition of the oil, remove the oil fill plug. Drain the chamber volume into a transparent container. Visually check sample for impurities or emulsification (oil may appear cream-like if a small amount of water is present). If significant water intrusion has occurred, remove and replace lower mechanical seal. Unless obvious mechanical damage has occurred to the lower seal, it is good practice to replace the upper and lower mechanical seals as a set. Refill seal chamber with fresh oil to the bottom of fill plug port (when pump is in vertical position) and replace oil fill plug.

6. IMPELLER

Periodically inspect impeller by turning pump on its side, remove suction strainer nuts and strainer to expose impeller and relocate position of adjusting plate (suction cover) as needed. Replace the impeller if it is damaged or worn.

SPARE PARTS

In order to obtain spare parts identify the required parts by looking at the enclosed cross sectional drawing and listing, and contact authorized HOMA PUMP TECHNOLOGY representative with your order. Authentic Homa Pump Technology parts shall be used to maintain warranty.

Note: Explosion Proof pumps must be identified as such, and the pump serial number must be referenced for proper parts identification.

RECOMMENDED TOOLS AND SUPPLIES

In addition to ordinary maintenance and lifting devices, ensure that complete set of metric Allen wrenches, impeller puller, Loctite 242 (Blue), and Anti-seize compound are on hand.

Wire Markings of Power & Control Cables

Wire Marker	Wire Connection	Normal Value
Power Cable (s)		
L3	Power Supply	See Wiring Diagram
L2	Power Supply	See Wiring Diagram
L1	Power Supply	See Wiring Diagram
Yellow/Green - Ground		
Control Cable (s)		
T1	Thermal Switch	N.C. .4 ohm
T2 or T3	Thermal Switch	N.C. .4 ohm
K1	Thermistor (optional)	N.C. 268 ohm
K2	Thermistor (optional)	N.C. 268 ohm
P1	Lower Bearing Temp. PT100	N.C. 108 ohm
P2	Lower Bearing Temp. PT100	N.C. 108 ohm
P3	Lower Bearing Temp. PT100	N.C. 108 ohm
P4	Lower Bearing Temp. PT100	N.C. 108 ohm
S1*	Oil Chamber Seal Probe	1 or 2 wire probe N.O.
S2	Oil Chamber Seal Probe	2 wire probe N.O.
S3	Connection Chamber Seal Probe	2 wire probe N.O.
S4	Connection Chamber Seal Probe	2 wire probe N.O.
S5*	Stator Housing Leak Detector	1 wire probe N.O.
S7	Stator Housing Leak Detector	Level Switch N.C. .7 ohm
S8	Stator Housing Leak Detector	Level Switch N.C. .7 ohm
Yellow/Green –Ground - *Must be used to complete 1 wire probe circuits!		

Note: Pump may have single or multiple power or control cables. Verify all wire connections are correct before applying power to any circuit. Improper power supply can permanently damage certain control devices.

All control or monitoring devices must be connected to a suitable power supply and sensing device. Homa can provide an optional Go Switch for any of these control or monitoring devices. Consult your local Homa distributor

PROFILE SEAL INSTALLATION

IMPORTANT

Black Rubber Sealing Ring (Profile Seal) must be installed in the Guide Claw before pump is installed. Ring must be installed with the large diameter lip inside the groove of the Guide Claw Flange.

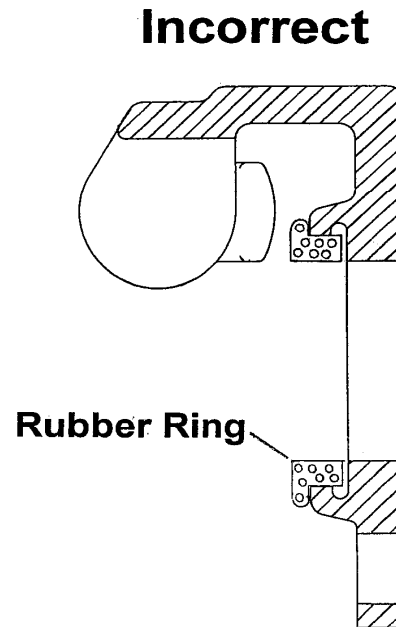
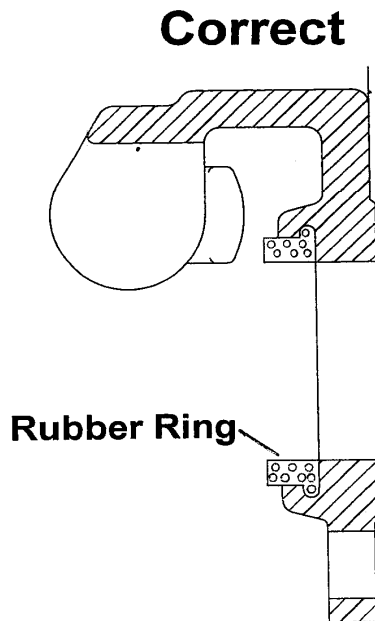

CALL OUR TECHNICAL SUPPORT GROUP WITH ANY QUESTIONS REGARDING THE INSTALLATION OF THIS EQUIPMENT.

SEAL PROBE INSTALLATION PROCEDURE

Mechanical Seal Leak Detection probe has been loose to protect from shipping damage. Please follow this procedure to install the probe.

- 1) Lay pump on its side with the plug on the seal chamber facing upwards as indicated.
- 2) Unscrew the plug with the proper wrench, taking care not to damage the sealing surface.
- 3) Verify that seal chamber oil level is within $\frac{1}{4}$ " of the indicated value. Measurement is from oil level to the top of hole. See IOM Manual for seal chamber oil volume, if required.
- 4) Remove the new sealing gasket from package and install it onto the seal probe plug.
- 5) Install the seal probe with gasket into the opening, taking care not to damage the cable. Then tighten the seal probe with the proper wrench until snug. Do not overtighten. Once tight, verify the seal gasket is properly seated and the cable is not pinched or twisted. *NOTE: At installation of the seal probe be careful not to bind the seal probe cord as it is being installed into the pump.*
- 6) Lift pump into a vertical position and inspect for any leaks.
- 7) Secure seal probe cable to pump body and power cable with tytraps before installing pump.

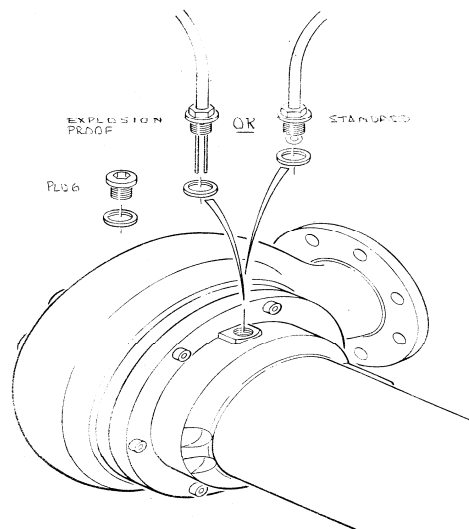

External Seal Probe Connections

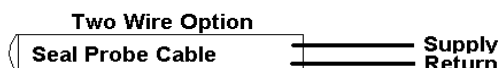
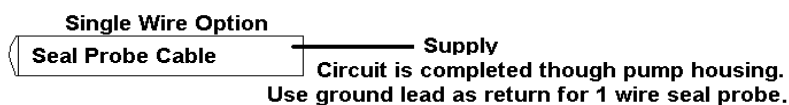

3 Phase Cable Connection Diagram

Note: If wire numbers or markers are different than shown, consult factory!

7 Conductor

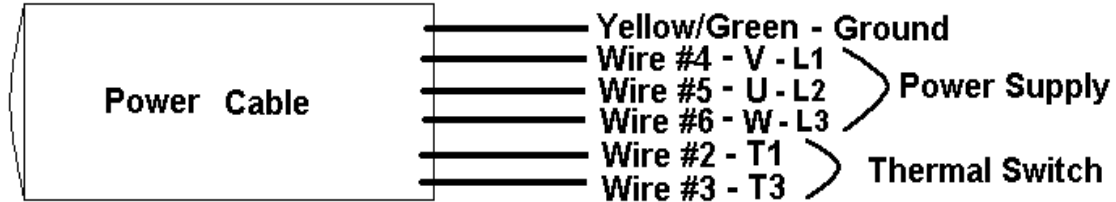

10 Conductor

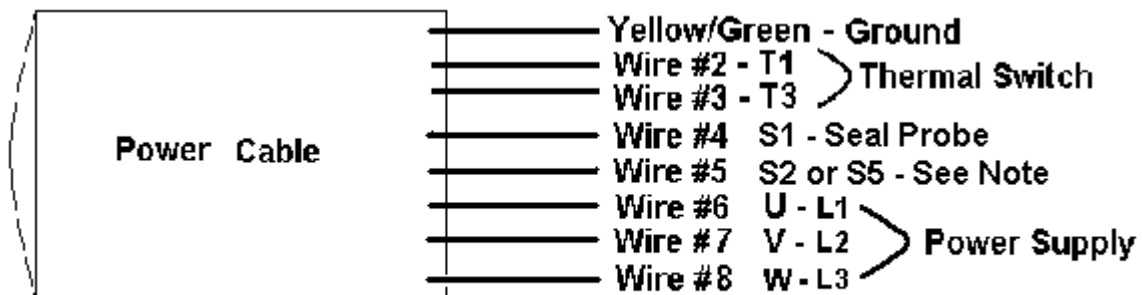

Note: S2 - Seal Probe (2 wire)
S5 - Stator Leakage Probe

Dual Power Cable

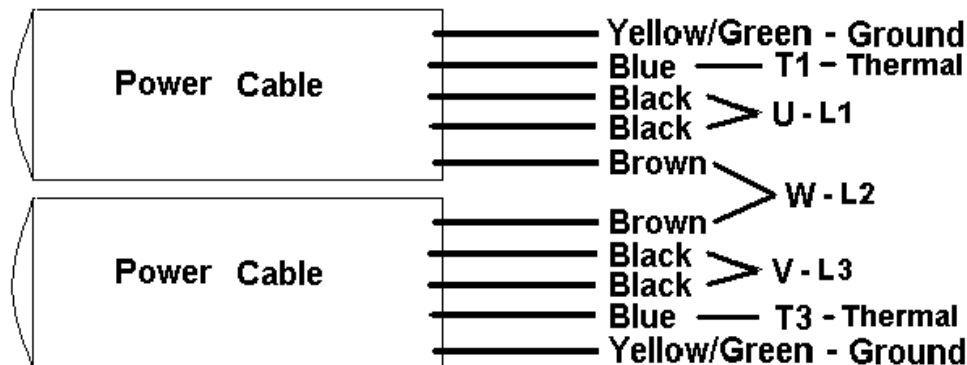

Power and Control Cable

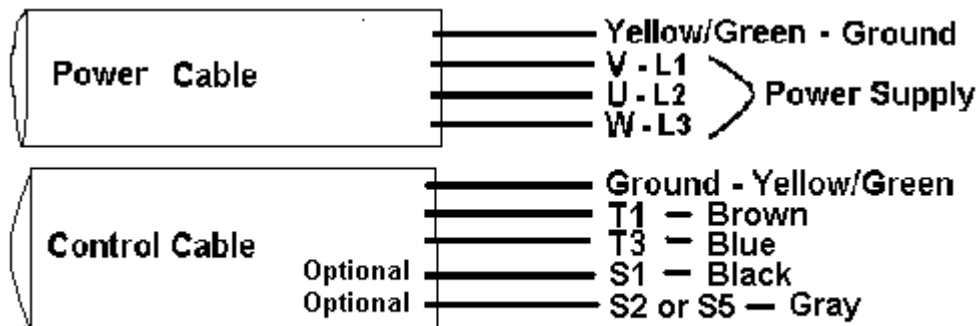

Note: S2 - Seal Probe (2 wire)
S5 - Stator Leakage Probe

3 Phase Cable Connection Diagram

Note: If wire numbers or markers are different than shown, consult factory!

Multiple Cable Configuration

Leads from multiple cables are combined to provide total load capability. 2 or more cables may be provided.

Typical

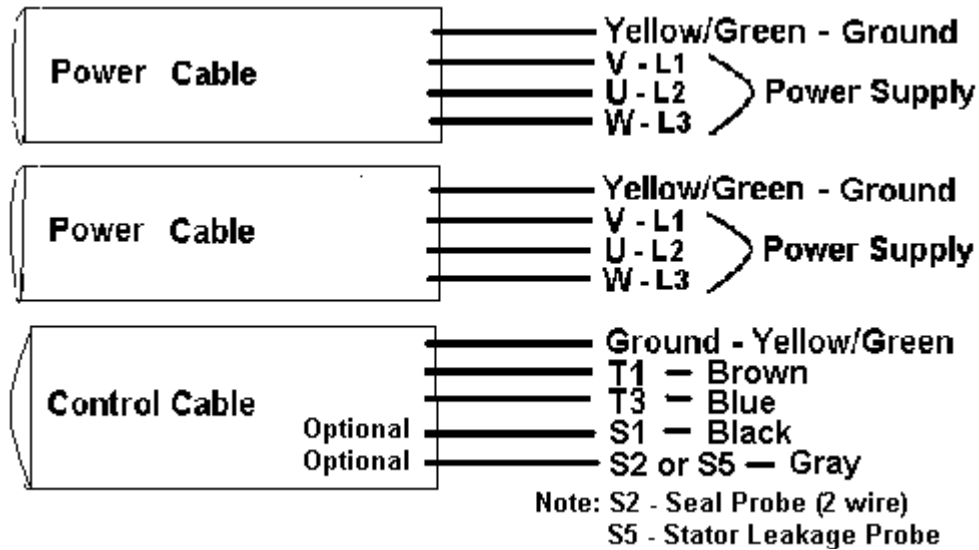

Dual Voltage Pumps Internal Wiring of Terminal Block

Dual Voltage pumps with terminal block will have wiring connected as indicated below. These units may be field converted to either 230v or 460v operation by reconnecting the jumpers as indicated below.

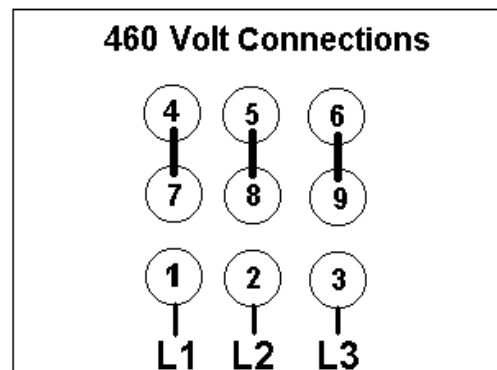
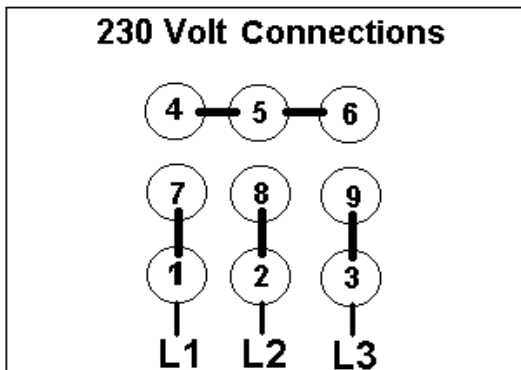

3 Phase Cable Connection Diagram T Motor

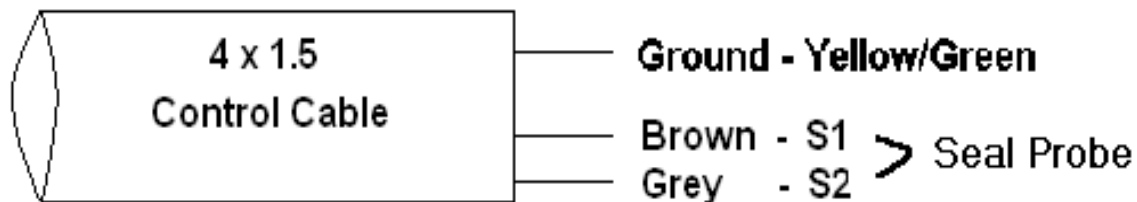
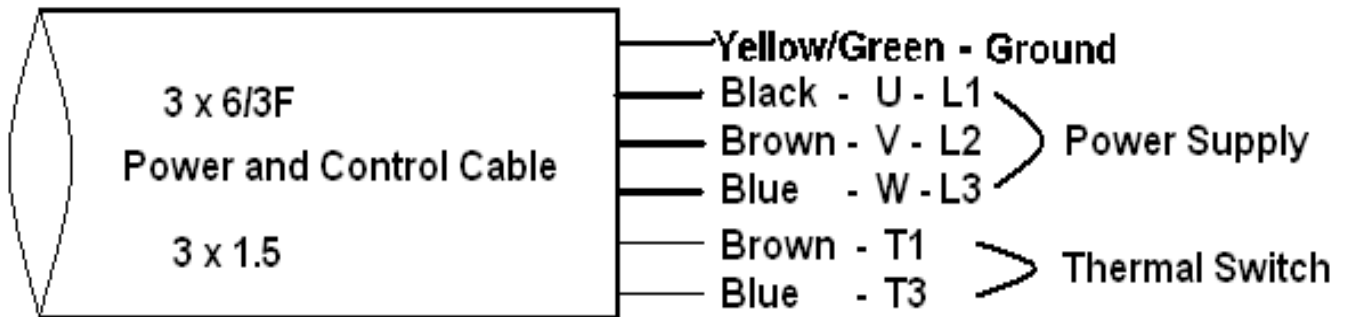

Single Phase Pump Start-Up Procedure

Run Capacitor sizing can vary depending on the incoming supply voltage provided. HOMA Single Phase pumps are provided with Start and Run Capacitor(s) sized for 220-230V under load. Frequently, the available line voltage is considerable different than indicated, and the Run capacitor(s) may need to be resized to match the available field voltage. The following procedure will allow you to verify proper operation of your single phase pump, and/or make necessary changes to you capacitors to correct for your power supply.

After verifying wiring is in accordance with your pump requirements, start pump and record the following readings from each of the (3) pump cable leads.

Current under load:

U1 _____ Amps, > U2 _____ Amps, > Z2 _____ Amps
Should be (highest reading) (middle reading) (lowest reading)

Lead U1 (common) should have the highest current reading. Lead Z2 (start) should have the lowest reading.

If Z2 current draw is greater than the current draw of either U1 or U2, a smaller size Run capacitor (lower microfarad rating) is required to correct the condition. Example: If a 60 uf Run capacitor was supplied, change to a 50 uf Run capacitor and check current readings. Typically, only one step down in capacitor size is required, but in certain instances 2 steps may be required.

() The standard capacitor kit provided includes: _____ uf start capacitor
_____ uf run capacitor.

() Additional run capacitors have been included for use in tuning the pump to match available line voltages for optimum performance.

_____ uf run capacitor

_____ uf run capacitor

_____ uf run capacitor

This form is provided for your use in optimizing the performance and service life of your single phase pumps, and is applicable to most Capacitor Start/Capacitor Run motors. Please contact our Technical Service Department @ 800-452-4662 with any questions or if you require any additional information or assistance.

1 Phase Cable Connection Diagram C, D, N & T Frame Motors *

Note: If wire numbers or markers are different than shown, consult factory!

7 Conductor Cable

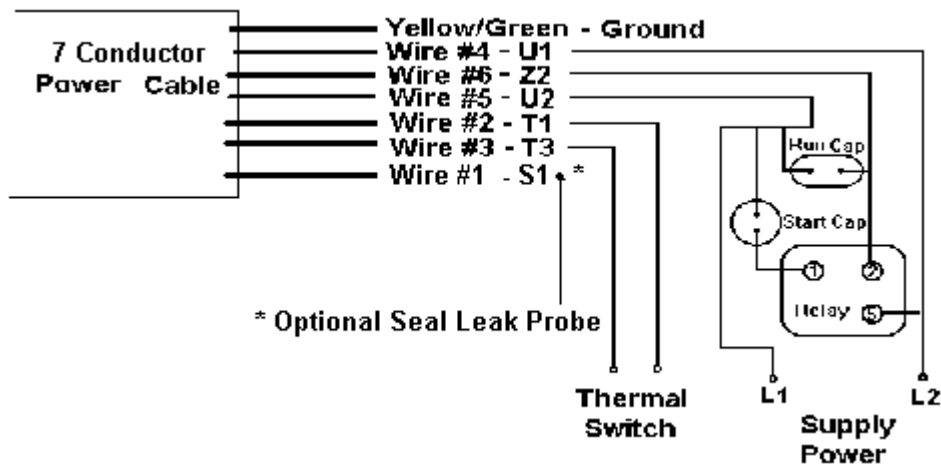

10 Conductor Cable

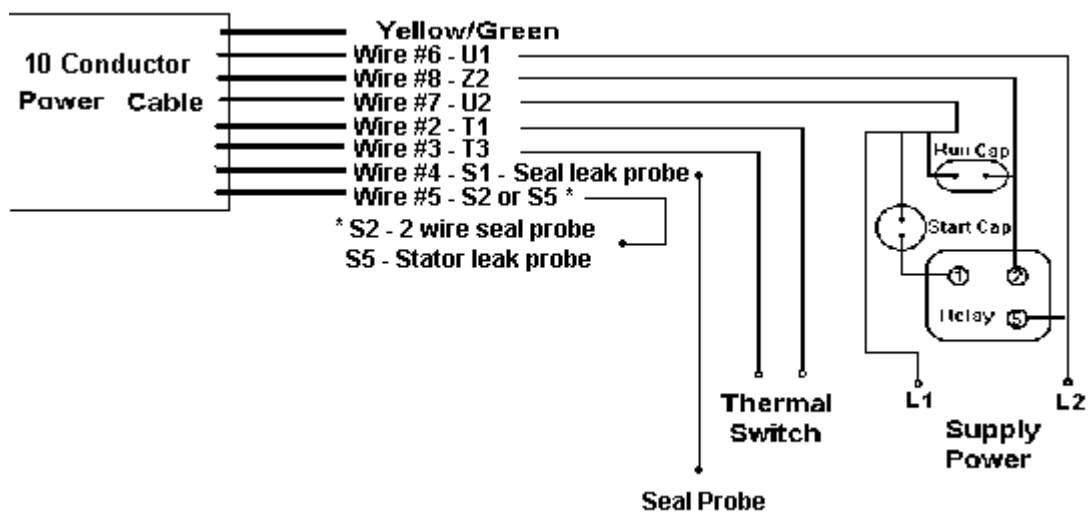

N Motor Capacitor Sizing Chart

Pump Model	Start Capacitor	Run Capacitor	Cap Kits
AMX334-434/1-142/2.9N	80uf @ 330V	40uf @ 370V	8857010
AMX334-434/1-155/4N	100uf @ 330V	50uf @ 370V	8857035
AMX334-434/1-178/4N	100uf @ 330V	50uf @ 370V	8857035
AMX334-434/1-184/5N	150uf @ 330V	80uf @ 370V	8857040
AMX334-434/1-193/5N	150uf @ 330V	80uf @ 370V	8857040
AMX334-434/1-193/7N	150uf @ 330V	100uf @ 370V+	8857045
AMX334-434/1-206/7N	150uf @ 330V	100uf @ 370V+	8857045
AMX334-434/1-206/10N	250uf @ 330V**	120uf @ 370V*	8857055
AMX334-434/1-218/10N	250uf @ 330V**	120uf @ 370V*	8857055
AMX334-434/1-228/10N	250uf @ 330V**	120uf @ 370V*	8857055

* (2) 60uf run capacitors in parallel are required.

+ (2) 50uf run capacitors in parallel are required.

** (1) 150uf & 100uf start capacitor in parallel required.

*Consult factory for A Frame motors with centrifugal switch.

External Seal Probe Wiring

Single Wire Option

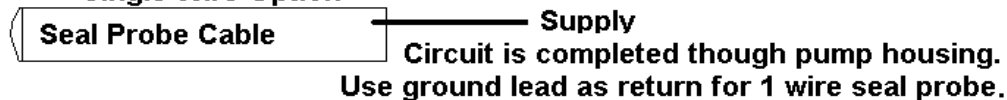

Two Wire Option



Seal Probes must be connected to a Homa Go Switch or suitable controller to operate.

C, D & T Motor Capacitor Sizing Chart

Pump Model	Start Capacitor	Run Capacitor	Cap Kits
AMX334-434/1-1422/C/C	80uf @330V	40uf @370V	8807010
AMX334-434/1-142/2.5D	80uf @ 330V	50uf @ 370V	8857060
AMX334-434/1-142/2.9T/C	60uf @ 330V	40uf @ 370V	8857065
AMX334-434/1-155/3.6D	80uf @ 330V	50uf @ 370V	8857060
AMX334-434/1-155/4.3T/C	100uf @ 330V	50uf @ 370V	8857035
AMX334-434/1-155/5.1T/C	100uf @ 330V	50uf @ 370V	8857035
AMX334-434/1-178/3.6D	80uf @ 330V	50uf @ 370V	8857060
AMX334-434/1-178/4.3T/C	100uf @ 330V	50uf @ 370V	8857035
AMX334-434/1-178/5.1T/C	100uf @ 330V	50uf @ 370V	8857035
AMX334-434/1-184/5.1T/C	100uf @ 330V	50uf @ 370V	8857035
AMX334-434/1-193/5.1T/C	100uf @ 330V	50uf @ 370V	8857035
AMX334-434/1-193/6.7T/C	120uf @ 330V	60uf @ 370V	8857070
AMX334-434/1-206/6.7T/C	120uf @ 330V	60uf @ 370V	8857070
AMX334-434/1-206/9.7T/C	150uf @ 330V	80uf @370V	8857075
AMX334-434/1-218/9.7T/C	150uf @330V	80uf @370V	8857075
AMX334-434/1-228/9.7T/C	150uf @330V	80uf @370V	8857075
AMX334-434/1-228/11.4T/C	250uf @330V**	120uf @370V*	8857080
AMX334-434/1-235/11.4T/C	250uf @330V**	120uf @370V*	8857080
AMX334-434/1-250/11.4T/C	250uf @330V**	120uf @370V*	8857080

* (2) 60uf run capacitors in parallel are required.

** (1) 150uf & 100uf start capacitor in parallel required.

*Consult factory for A Frame motors with centrifugal switch.

External Seal Probe Wiring

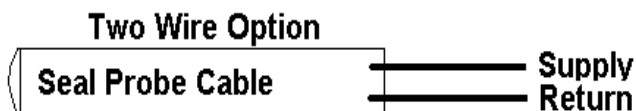
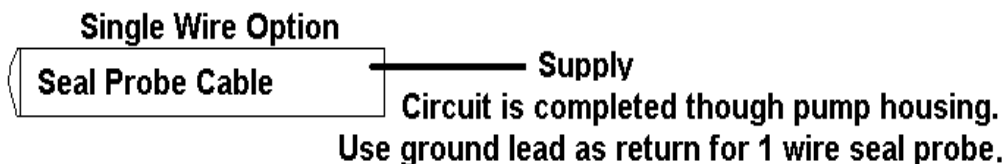

Seal Probes must be connected to a Homa Go Switch or suitable controller to operate.

START-UP REPORT

This report is designed to insure the customer that customer service and a quality product are the number one priority with HOMA Pump Technology, Inc. Please answer the following questions completely and as accurately as possible. Mail this form to:

**HOMA PUMP TECHNOLOGY INC.
390 BIRMINGHAM BOULEVARD
ANSONIA, CT 06401
ATTN: SERVICE MANAGER**

**Receipt of completed report will initiate operational warranty.
Reports that are not returned can delay or void warranty.**

- 1.) Pump User's Name: _____
Site Location: _____
Site Contract: _____
Unit Supplied By: _____

- 2.) HOMA Pumps Model _____ Serial No. _____
Voltage _____ Phase _____ Hertz _____ Horsepower _____
Method Used to Check Rotation (viewed from bottom) _____
Does Impeller Turn Freely By Hand: YES _____ NO _____

- 3.) Condition of Equipment: EXCELLENT _____ GOOD _____ AVERAGE _____
Condition of Cable Jacket : EXCELLENT _____ GOOD _____ AVERAGE _____
Resistance of Cable and Pump Motor (measured at pump control)
1 Phase: U1 – U2 _____ Ohms; U1 - Z2 _____ Ohms; U2 – Z2 _____ Ohms; T1 – T2 _____ Ohms
3 Phase: U - V _____ Ohms; V - W _____ Ohms; U -W _____ Ohms, T1 – T2 _____ Ohms

Resistance of Ground Circuit Between Control Panel and Outside of Pump _____ Ohms
MEG Ohm Check of Insulation:
U to Ground _____ V to Ground _____ W to Ground _____

- 4.) Condition of Equipment at Start-Up: Dry _____ Wet _____ Muddy _____
Was Equipment Stored: _____ Length of Storage _____
Describe Station Layout _____

- 5.) Liquid Level Controls: Model _____ Type _____
Is Control Installed Away From Turbulence? _____
Operation Check: (IF FLOAT SWITCHES SUPPLIED).
Tip lowest float (stop float), all pumps should remain off.
Tip second float (and stop float), one pump comes on.
Tip third float (and stop float), both pumps on (alarm on simplex).
Tip fourth float (and stop float), high level alarm on (omit on simplex).

- 6.) Electrical Readings:
Single Phase:
Voltage Supply at Panel Line Connection, **Pump Off**, L1- L2 _____ L1-Ground _____ L2-Ground _____
Voltage Supply at Panel Line Connection, **Pump On**, L1- L2 _____ L1-Ground _____ L2-Ground _____
Amperage: Load Connection, **Pump On**, U1 _____ U2 _____ Z2 _____
Resistance Across Thermal Switch leads T1-T2 _____ ohms

Three Phase:
Voltage Supply at Panel Line Connection, **Pump Off**, L1-L2 _____ L2-L3 _____ L3-L1 _____
Voltage Supply at Panel Line Connection, **Pump On**, L1-L2 _____ L2-L3 _____ L3-L1 _____
Amperage Load Connection, **Pump On**, L1 _____ L2 _____ L3 _____
Resistance Across Thermal Switch leads T1-T2 _____ ohms

7.) Starting Devices

Are pumps being started DOL, or with Soft Start device. Indicate manufacturer of Soft Starter. _____
Are any vibrations evident while pump is being controller by the soft starter? _____
Are pumps being operated with VFD (Variable Frequency Drive)? _____
Please indicate brand and model VFD: _____
Are load reactors being used between VFD output and pump? _____ Please indicate size _____
What ramp up and decel time is the VFD set for? Accel _____ seconds, Decel: _____ seconds
What is the minimum frequency the pump can operate at in this system? _____ Hz. Is low speed limit set? _____

8.) Final Check:

Are Thermal Switches properly wired? _____ What Over-temperature Relay is being used? _____
Is Pump Seated On Discharge Properly? _____ Check For Leaks? _____
Does Check Valves Operate Properly? _____
Flow: Does Station Appear To Operate At Proper Rate _____
Vibration Level: Measured _____ Observed _____
Has the cooling jacket been vented? _____ Is a permanent cooling jacket vent installed? _____

COMMENTS: _____

9.) Equipment Difficulties During Start-Up: _____

10.) I Certify this Report to be accurate.

Authorized Homa Service Representative:

(Signature) Phone # _____

DATE _____

Pump Station Owner/ Operator

(Signature) Phone # _____

DATE _____

A Series Technical Details

The following is offered as a general guide to values and capacities commonly used.

HP / RPM	Resistance Readings (ohms)				Pump Weight Approx. (Lbs.)
	230V 1 Phase U1 - U2 / U1 - Z2		230V 3 Phase * U-V-W		
2.5HP-1750 D	2.2	5.0	1.5	5.0	230 #
2.8HP-1160 T	N/A		2.7	5.0	230 #
2.9HP-1750 N	2.2	5.0	3.1	11.0	230 #
2.9HP-1750 T			3.1	11.0	230 #
3.5 HP 1750 D	N/A		1.9	5.5	230 #
3.8HP-1160 T	N/A		1.5	2.5	240 #
4.3HP-1750 N	1.5	3.0	1.5	4.2	240 #
4.3HP-1750 T			1.5	4.2	240#
5.1HP- 1750T	1.1	2.6	N/A	N/A	250#
5.5HP-1750 N	.9	1.9	1.3	3.7	250 #
5.5HP-1750 T	N/A		1.3	3.7	250#
6.2HP-1160 T	N/A		1.3	3.7	250 #
6.7HP- 1750T	0.7	1.9	N/A	N/A	260#
7.5HP-1750 N	.8	1.5	0.9	2.6	260 #
7.5HP-1750 T	N/A		1.2	3.0	260#
8.3HP-1160 T	N/A		0.9	2.6	260 #
9.7HP –1750 T	0.5	1.4	N/A	N/A	260#
9.8HP-1160 P	N/A		0.7	2.2	290 #
10HP-1750 N	0.3	0.9	0.6	1.9	290 #
10HP-1750 T	N/A		0.6	1.9	290#
11.4HP – 1750 T	0.4	0.8	N/A	N/A	290#
13HP-1750 P	N/A		0.5	1.8	350 #
15.3HP-1160 P	N/A		0.5	1.1	350 #
20HP-1750 P	N/A		0.5	1.1	400 #
21.5HP-1160 P	N/A		0.5	1.1	400 #
29HP-1750 P	N/A		0.4	0.7	500 #

*Values should be as indicated between any 2 power leads.

Note: Resistance values include 30' cable, and should be within +/- 10% of above value.

Above 30 HP, resistance values between 230 and 460 volt machines vary by less than 0.1 ohm. Consult factory with specific requirements.

Impeller Bolt Torque: 10MM- 26FT#, 12MM-45FT#, 16MM-108FT#, 20MM- 210FT#

Impeller to Bottom Plate Clearance: (ASC) .020" minimum clearance.

Pump Rotation Right hand (CW) looking down from top of motor, CCW looking at bottom of pump.

Seal Probes: N motor pumps use a 12mm seal probe P motor pumps use 20mm seal probe.

Single wire probes are for non classified areas, and 2 wire probes are for Hazardous areas.

A Series Technical Details

Seal Chamber Oil: White Mineral Oil (Chevron Lubricating Oil FM 32, 46, 68)

Seal Oil Volume

ALL N FRAME MOTORS 2.5L

ALL T FRAME MOTORS 2.5L

ALL P FRAME MOTORS 3.7L

CURRENT D MOTORS .9L

F, G & H FRAME SEAL OIL VOLUTE VARY BY HP, PLEASE CONSULT FACTORY WITH SPECIFIC PUMP MODEL.

Seal Oil Level

With pump lying on its side and oil port at 12:00, measure from the top of housing with gasket in place, to the oil level.

A Series T, N & P motors: 1 1/2" from top of housing to oil level

Minimum Distance between 2 pumps

	3" Discharge	4" Discharge	6" Discharge	8" & Larger
AK	Min N/A	Min 10"	Min 13"	Please consult factory for lay- out information
AV	Min N/A	Min 10"	Min N/A	
AMX	Min 8"	Min 10"	Min 13"	